

Instructions - Kemp® Dri-Breather

Purpose

Kemp Dri-Breathers are designed to remove moisture from ambient air drawn into liquid storage tanks as they are drained. Kemp Dri-Breathers also prevent moisture from entering during daily temperature changes, which cause the air inside the tank to expand or contract.

General Description

When in use, as the liquid storage tank is drained or pumped down, air is drawn into the Dri-Breather through the air inlet. It flows through the desiccant bed and then into the storage tank. Supervision is not required during operation except to periodically inspect the moisture indicator observation port.



**Kemp DB-12 Dri-Breather
w/Manifold & Support Frame**



**Kemp DBR-3 Dri-Breather
Reactivator**

Installation

The Dri-Breather should be installed in a vertical position in a suitable location. A standard flanged connection is provided on the bottom head of the vessel. If the Dri-Breather is used on the vent of a storage tank containing acid or other corrosive liquid or vapor, check valves should be installed between the Dri-Breather and the storage tank. This is necessary to prevent the corrosive vapors from entering the Dri-Breather vessel and contaminating the adsorbent. Refer to the picture for typical piping. Contact Kemp for check valves and check valve manifolds approved for this application.

Maintenance

The only normal maintenance required is to periodically reactivate or replace the Dri-Breather adsorbent when it becomes saturated. The need for reactivation or replacement of the adsorbent is indicated when the color in the moisture indicator observation port changes from a definite blue through light blue to pink or white. Reactivation may be accomplished using a Kemp Reactivator designed for this purpose. Refer to Bulletin V-104 for Kemp Dri-Breather Reactivator instructions.

To replace the adsorbent, remove the Dri-Breather from the system. Remove the threaded screened nozzle from the vessel and pour the saturated adsorbent from the vessel. Refill the vessel with the volume of fresh adsorbent specified on the opposite side of this instruction sheet. Replace the screened nozzle and any other fittings removed. The moisture indicator observation port color should return to a definite blue color a few hours after the adsorbent is changed. If it does not, the indicator must be replaced with Kemp cat# 30168. The Dri-Breather may now be returned to service.

If uninterrupted service is required, two Dri-Breathers should be maintained to permit one to be ready for service when the other is in need of regeneration.

WARNING

1. If flammable vapors are present, a flame arrester should be installed to prevent flame propagation from entering the storage tank. Refer to the diagram for typical piping.
2. Failure to install and service sensitive check valves in systems containing corrosive vapors will result in contamination of the adsorbent. Contaminated adsorbent must be handled and disposed of following Federal and/or local EPA guidelines.



NOTE: "Kemp's commitment with respect to any systems described herein or any warranty related thereto shall be set forth exclusively in the contract of sale between Kemp and the customer. The information set out in this brochure is for preliminary information only, and is not intended to constitute any representation or warranty by Kemp to potential customers or to form the basis of a contract with any customer. Kemp makes no guarantee of satisfactory results from the reliance of information or recommendations herein, and disclaims all liability for any resulting loss or damage."

SPX Kemp • 4647 S.W. 40th Avenue • Ocala, Florida 34474-5799-USA
Phone 352-873-5123 • Fax 352-873-5187

Item	Part No.	Description
1	0012455	Upper Screen Nozzle
2	1262232	Dri-Breather Adsorbent, 30 lbs.
3	0012455	Lower Screen Nozzle
4	0011684	Flange, 1 1/2" 125 lb. FF CI
5	0030168	Observation Port

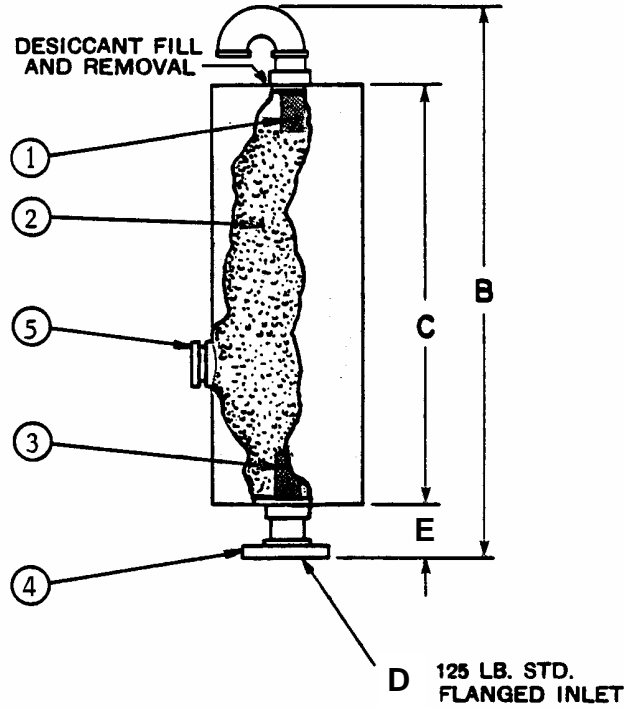

Model Number	Catalog Number	Avg. Flow CFM/GPM	Press. Drop @ Avg. Flow	Weight (Pounds)		Rated Lb. H ₂ O	Dimensions (Inches)				
				Charged	Dscc. Charge		Dia.	B	C	D	E
DB-5	0011400	0.5 / 3.8	0.24" W.C.	60	8	1.0	5 7/8	32 1/2	25 1/8	1 1/2	2 1/4
DB-6	0011396	1.0 / 7.5	0.31" W.C.	75	15	2.0	6 7/8	32 1/2	25 1/8	1 1/2	2 1/4
DB-8	0011399	1.5 / 11.3	0.30" W.C.	95	25	3.5	8 7/8	34 7/8	24 3/8	1 1/2	3 13/16

Notes:

1. Maximum flow should not exceed 3 times average flow.
2. Indicator gel in the observation port, item-5, will change color, from blue to pink, to indicate when the Dri-Breather requires reactivation or adsorbent change.



**DRI-BREATHER
MODELS DB5 – DB8**

DRAWING NUMBER

V-100

Cat. # 1263766

SEE REVERSE SIDE

Item	Part No.	Description
1	0012455 0012458	Upper Screen Nozzle DB-12 Upper Screen Nozzle DB-16 & 20
2	1262232 1262233 1262234	Dri-Breather Adsorbent, 30 lbs. Dri-Breather Adsorbent, 150 lbs. Dri-Breather Adsorbent, 300 lbs.
3	*	Lower Screen Nozzle
5	0030168	Observation Port

* Lower screen nozzle is not removable.

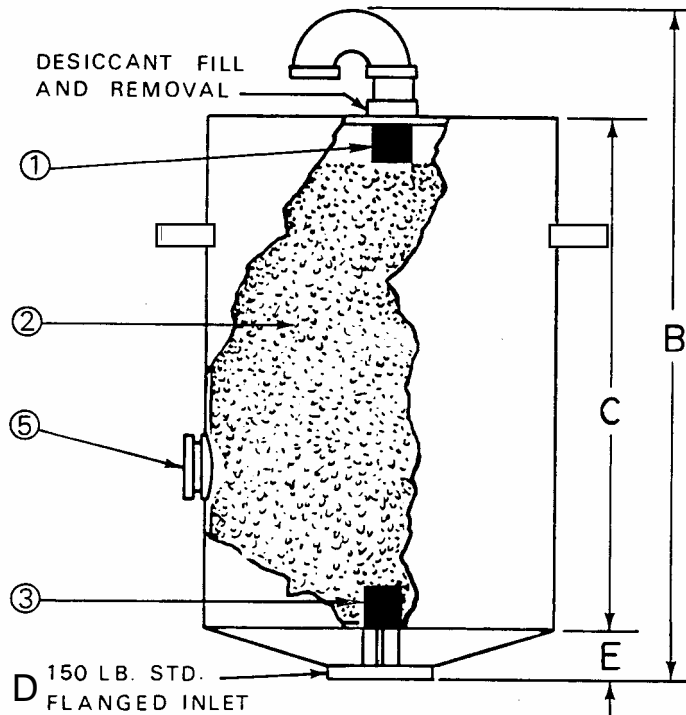

Model Number	Catalog Number	Avg. Flow CFM/GPM	Press. Drop @ Avg. Flow	Weight (Pounds)		Rated Lb. H ₂ O	Dimensions (Inches)				
				Charged	Dsc. Charge		Dia.	B	C	D	E
DB-12	11397	3 / 22	0.26" W.C.	140	50	7.5	12	34 ¹⁵ / ₁₆	24 ³ / ₈	1 ¹ / ₂	3 ⁷ / ₈
DB-16	11398	7.5 / 56	0.41" W.C.	220	100	15.0	16	37 ³ / ₄	27 ³ / ₁₆	2	3 ³ / ₈
DB-20	11395	15 / 112	0.52" W.C.	320	175	26.0	20	38 ³ / ₄	28 ³ / ₁₆	2	3 ³ / ₈

Notes:

1. Maximum flow should not exceed 3 times average flow.
2. Indicator gel in the observation port, item-5, will change color, from blue to pink, to indicate when the Dri-Breather requires reactivation or adsorbent change.



**DRI-BREATHER
MODELS DB12 – DB20**

DRAWING NUMBER

V-101

Cat. # 1263765

SEE REVERSE SIDE